



**3-5300 SERIES  
SAFETY RELIEF  
VALVES**



## 3-5300 SERIES SAFETY RELIEF VALVES



Available styles of 3-5300 valves are summarised in the following table:

Model	Description	Bonnet	Fluid
3-5311	conventional	closed	gas and liquid
3-5313		open	gas (1)
3-5314			
3-5361	bellows balanced	closed (2)	gas and liquid
3-5363		open	gas (1)
3-5364			

(1) Compressible fluids which are permitted to escape into the atmosphere (e.g. air or steam)

(2) Bonnet is vented to the atmosphere by means of a vent hole

The bellows type 3-5361, 3-5363, 3-5364 are used to insure that the back-pressure does not affect the set pressure or when the bonnet must be isolated from highly corrosive, viscous, fouling or dangerous media.

### MAIN FEATURES

#### BODY

- construction forged steel
- sizes: 1/2 "x3/4", 1 1/2"x1 ", 3/4"x1", 1 "x1 ", 1"x1.1/2"  
NPT 1/2"x3/4", 1/2"x1" and 3/4"x1" are available from stock screwed and flanged as listed in the following tables.  
Welding ends are available, on request.
- connections
- screwed construction ratings: nozzle: 2000 and 3000 classes (6000 class on request)  
body: 2000 class  
For P/T decays refer to corresponding ASME ratings
- flanged construction ratings:
  - inlet: UNI PN 167100  
ANSI 150÷600
  - outlet: UNI PN 16÷100  
ANSI 150÷600
 Inlet flanged constructions up to ANSI 1500 available on request.

### GENERAL

Parcol 3-5300 series safety relief valves are PED approved.

Their main features are:

- high discharge capacity
- full nozzle screwed into the body
- upper guided self-centering plug
- blow-down ring screwed on the nozzle and adjustable from outside

**NOZZLE**

- construction : from barstock
- mounting : screwed and guided inside the body
- orifices : B(a), C, C(a), D, D(a), D(a1), E, E(a)
  - The orifices with suffix (a) refer to valves used on liquid service.
  - Valves bellows balanced are available with D(a1) and E(a) orifices only.

**PLUG**

- construction : two pieces (disc and disc holder) coupled by an elastic pin.
- guiding : pivoting on the stem (which is upper guided in the body).

**BONNET**

- construction : from bar. The standard bonnet is closed type and always at valve outlet pressure assured by means of a hole on the guide. On request, an open bonnet can be supplied when cooling of spring is needed (on all standard constructions).

**CAP**

- construction : from bar. It is available with or without lifting lever.
- fittings : on request:
  - test gag chained to the sealing plug of the cap
  - seal wire between cap and bonnet, to prevent unauthorized spring adjustment.

**LIFTING LEVER**

- construction : cam shaft mechanism gas tight.

**FUNCTIONAL FEATURES**

Functional features of Parcol 3-5300 series are shown in the following table:

Service	Discharge coefficient (K <sub>D</sub> or K <sub>L</sub> )	Max overpressure <sup>(1)</sup>	Max backpressure <sup>(2)</sup>
Gas and steam	0.90 <sup>(3)</sup>	10%	25%
Liquid	0.397 <sup>(3)(4)</sup>	10%	50%
	0.620 <sup>(3)(4)</sup>	25%	

- 1) Minimum value = 0.2 bar for gas and 0.3 bar for liquid
- 2) Value valid for bellows balanced valves
- 3) PED certified value
- 4) According to API RP 520

Blow down values widely fulfil the actual reference standards.

Adjusting of set pressure :  $\pm 10\%$  for  $p_{set} \leq 17$  bar and  $\pm 5\%$  for  $p_{set} > 17$  bar.

**MAX INLET SET PRESSURES <sup>(1) (2)</sup>**

SERIES	ORIFICES	Class 3000 <sup>(3)</sup>	
		Max set pressure - bar	
		St. steel spring	Carbon steel spring
1st SERIES 3-5311 3-5361	B(a)-C	165	165
	C(a)-D	78	130
	D(a)-E	48	70
	D(a1)-E(a)	36	48
2nd SERIES 3-5313 3-5363	C(a)-D	210 <sup>(4)</sup>	210 <sup>(4)</sup>
	D(a)-E	115	180
	D(a1)-E(a)	78	115
2nd SERIES L 3-5314 3-5364	C(a)-D	210 <sup>(4)</sup>	210 <sup>(4)</sup>
	D(a)-E	200	210 <sup>(4)</sup>
	D(a1)-E(a)	130	210

- (1) The set pressure can not exceed the max rating pressure (max 100 bar for PN 100, ANSI 600; max 140 bar for class 2000)
- (2) These values are valid for fluid temperatures listed in spring subclass table
- (3) Hydrostatic pressure test of nozzle = 315 bar
- (4) A special class 6000 type with higher set pressure and test pressure of nozzle at 630 bar is also available

ORIFICE	Orifice diameter mm	Orifice area cm <sup>2</sup>	Thrust diameter mm	Thrust area cm <sup>2</sup>	Lift mm
B(a)	5.7	0.25	8.7	0.6	2
C	8	0.5	8.7	0.6	2.5
C(a)	8	0.5	11.5	1.04	2
D	10	0.78	11.5	1.04	3
D(a)	10	0.78	15	1.77	3
D(a1)	10	0.78	18.5	2.69	3
E	13.5	1.43	15	1.77	4.5
E(a)	13.5	1.43	18.5	2.69	4

## TEMPERATURE LIMITS OF BELLOWS (AISI 316L)

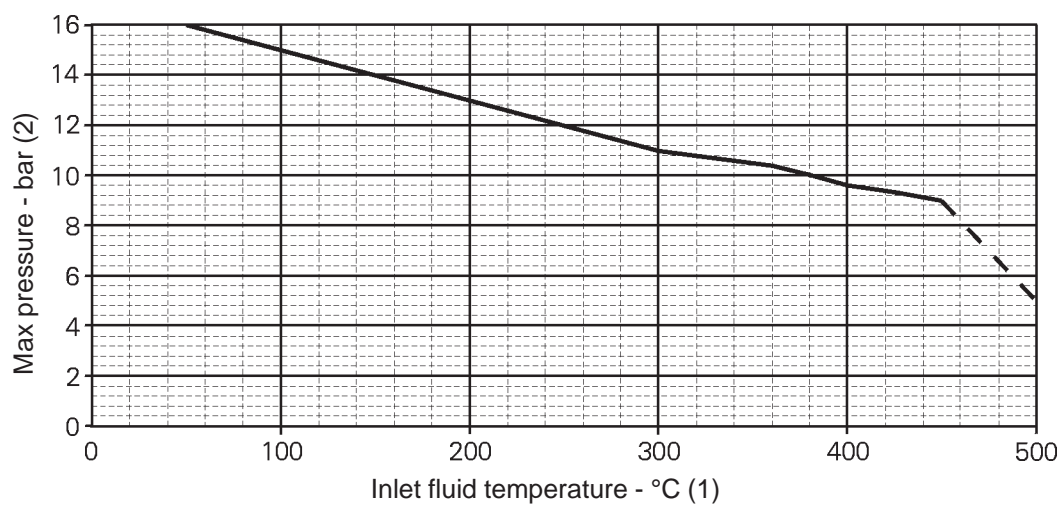

- (1) Over 450 °C the use of bellows must be avoided, due to the critical fall of its elastic properties  
(2) Max pressure limits comply with the API std. 526/1995

CONVENTIONAL CONSTRUCTION

		Rating		DN - in.		Orifice (4)	A	B	C	D	Mass kg (3)		
		Inlet	Outlet	Inlet	Outlet								
	1 <sup>st</sup> series 3-5311	Nozzle: 2000-3000-6000 classes Threading type: cylinder ISO-NPT	Body: 2000 class Threading type: cylinder ISO-NPT	1/2	3/4	B(a)-C-C(a)-D-D(a)	50	60	255		3,5		
	2 <sup>nd</sup> series 3-5313			1/2	1	B(a)-C-C(a)-D-D(a)							
				3/4	1	C(a)-D-D(a)-E-E(a)							
				3/4	1	C(a)-D-D(a)-E-E(a)							
	2 <sup>nd</sup> series L 3-5314			1	1	D(a)-E-E(a)	60	75	300			6	
				1	1.1/2	D(a)-E-E(a)							
				3/4	1	C(a)-D-D(a)-E-E(a)							
				1	1	D(a)-E-E(a)							
				1	1.1/2	D(a)-E-E(a)	60	75	327			6,5	
				1	1	D(a)-E-E(a)							
1		1.1/2	D(a)-E-E(a)										
1		1.1/2	D(a)-E-E(a)										
	1 <sup>st</sup> series 3-5311	Nozzle: 2000-3000-6000 classes Threading type: cylinder ISO-NPT	Body: 2000 class Threading type: cylinder ISO-NPT	1/2	3/4	B(a)-C-C(a)-D-D(a)	50	80	275		3,5		
	2 <sup>nd</sup> series 3-5313			1/2	1	B(a)-C-C(a)-D-D(a)							
				3/4	1	C(a)-D-D(a)-E-E(a)							
				1	1	C(a)-D-D(a)-E-E(a)							
	2 <sup>nd</sup> series L 3-5314			3/4	1	C(a)-D-D(a)-E-E(a)	60	90	315			6	
				1	1	D(a)-E-E(a)							
				1	1.1/2	D(a)-E-E(a)							
				3/4	1	C(a)-D-D(a)-E-E(a)							
				1	1	D(a)-E-E(a)	60	90	342			6,5	
				1	1	D(a)-E-E(a)							
1		1.1/2	D(a)-E-E(a)										
1		1.1/2	D(a)-E-E(a)										
	1 <sup>st</sup> series 3-5311	UNI PN 16 ÷ 100 ANSI 150 ÷ 600		UNI PN 16 ÷ 40 ANSI 150 ÷ 300	1/2	3/4	B(a)-C-C(a)-D	90	95	290	31	4	
					1/2	1	B(a)-C-C(a)-D						
					3/4	1	C(a)-D-D(a)-E-E(a)						
					1	1	C(a)-D-D(a)-E-E(a)						
	2 <sup>nd</sup> series 3-5313				UNI PN 64 ÷ 100 ANSI 600	1/2	3/4	B(a)-C-C(a)-D	95	95	290	31	4
						1/2	1	B(a)-C-C(a)-D					
						3/4	1	C(a)-D-D(a)-E-E(a)					
						1	1	C(a)-D-D(a)-E-E(a)					
	2 <sup>nd</sup> series L 3-5314				UNI PN 16 ÷ 40 ANSI 150 ÷ 300	3/4	1	C(a)-D-D(a)-E-E(a)	105	105	300	35	5
						1	1	C(a)-D-D(a)-E-E(a)					
						3/4	1	C(a)-D-D(a)-E-E(a)					
						1	1	C(a)-D-D(a)-E-E(a)					
					UNI PN 64 ÷ 100 ANSI 600	3/4	1	C(a)-D-D(a)-E-E(a)	105	110	335	33	7,5
						1	1	C(a)-D-D(a)-E-E(a)					
						3/4	1	C(a)-D-D(a)-E-E(a)					
						1	1	C(a)-D-D(a)-E-E(a)					
		UNI PN 16 ÷ 40 ANSI 150 ÷ 300	3/4	1	C(a)-D-D(a)-E-E(a)	105	110	362	33	8			
			1	1	C(a)-D-D(a)-E-E(a)								
			3/4	1	C(a)-D-D(a)-E-E(a)								
			1	1	C(a)-D-D(a)-E-E(a)								
		UNI PN 64 ÷ 100 ANSI 600	3/4	1	C(a)-D-D(a)-E-E(a)	110	110	362	33	8			
			1	1	C(a)-D-D(a)-E-E(a)								
			3/4	1	C(a)-D-D(a)-E-E(a)								
			1	1	C(a)-D-D(a)-E-E(a)								
	1 <sup>st</sup> series 3-5311	ANSI 300 ÷ 1500	ANSI 150 ÷ 600	1/2	3/4	B(a)-C-C(a)-D-D(a)-E-E(a)	110	150	345		4		
	2 <sup>nd</sup> series 3-5313			1/2	1	B(a)-C-C(a)-D-D(a)-E-E(a)							
				3/4	1	C(a)-D-D(a)-E-E(a)							
				3/4	1	C(a)-D-D(a)-E-E(a)							
	2 <sup>nd</sup> series L 3-5314			1	1	C(a)-D-D(a)-E-E(a)	150	150	375			6,5	
				1	1.1/2	C(a)-D-D(a)-E-E(a)							
				3/4	1	C(a)-D-D(a)-E-E(a)							
				1	1	C(a)-D-D(a)-E-E(a)							
				1	1.1/2	C(a)-D-D(a)-E-E(a)	150	150	402			7	
				1	1	C(a)-D-D(a)-E-E(a)							
	1	1.1/2	C(a)-D-D(a)-E-E(a)										
	1	1	C(a)-D-D(a)-E-E(a)										

**BELLOWS BALANCED CONSTRUCTION**

		Rating		DN - in.		Orifice (4)	A	B	C	D	Mass kg (3)		
		Inlet	Outlet	Inlet	Outlet								
	1 <sup>st</sup> series 3-5361	Nozzle: 2000-3000-6000classes Threading type: cylinder ISO-NPT	Body: 2000 class Threading type: cylinder ISO-NPT	1/2	3/4	D(a1)	50	60	292		4		
				1/2	1	D(a1)							
				3/4	1	D(a1)-E(a)							
	2 <sup>nd</sup> series 3-5363			2 <sup>nd</sup> series L 3-5364	3/4	1	D(a1)-E(a)	60	75	334			6,5
					1	1	D(a1)-E(a)						
					1	1.1/2	D(a1)-E(a)						
2 <sup>nd</sup> series L 3-5364	2 <sup>nd</sup> series L 3-5364	3/4	1	D(a1)-E(a)	60	75	361			7			
		1	1	D(a1)-E(a)									
		1	1.1/2	D(a1)-E(a)									
	1 <sup>st</sup> series 3-5361	Nozzle: 2000-3000-6000classes Threading type: cylinder ISO-NPT	Body: 2000 class Threading type: cylinder ISO-NPT	1/2	3/4	D(a1)	50	80	312		4		
				1/2	1	D(a1)							
				3/4	1	D(a1)-E(a)							
	2 <sup>nd</sup> series 3-5363			2 <sup>nd</sup> series L 3-5364	3/4	1	D(a1)-E(a)	60	90	349			6,5
					1	1	D(a1)-E(a)						
					1	1.1/2	D(a1)-E(a)						
2 <sup>nd</sup> series L 3-5364	2 <sup>nd</sup> series L 3-5364	3/4	1	D(a1)-E(a)	60	90	376			7			
		1	1	D(a1)-E(a)									
		1	1.1/2	D(a1)-E(a)									
	1 <sup>st</sup> series 3-5361	UNI PN 16 ÷ 100 ANSI 150 ÷ 600	UNI PN 16 ÷ 40 ANSI 64 ÷ 100 600	3/4	1	D(a1)-E(a)	95	100	332	33	5,5		
				1	1	D(a1)-E(a)							
				3/4	1	D(a1)-E(a)							
				1	1	D(a1)-E(a)							
	2 <sup>nd</sup> series 3-5363			2 <sup>nd</sup> series L 3-5364	UNI PN 16 ÷ 40 ANSI 150 ÷ 300	3/4	1	D(a1)-E(a)	105	110	369	33	8
					1	1	D(a1)-E(a)						
					UNI PN 64 ÷ 100 ANSI 600	3/4	1	D(a1)-E(a)					
					1	1	D(a1)-E(a)						
	2 <sup>nd</sup> series L 3-5364			2 <sup>nd</sup> series L 3-5364	UNI PN 16 ÷ 40 ANSI 150 ÷ 300	3/4	1	D(a1)-E(a)	105	110	396	33	8,5
					1	1	D(a1)-E(a)						
					UNI PN 64 ÷ 100 ANSI 600	3/4	1	D(a1)-E(a)					
					1	1	D(a1)-E(a)						
2 <sup>nd</sup> series L 3-5364	2 <sup>nd</sup> series L 3-5364	UNI PN 16 ÷ 40 ANSI 150 ÷ 300	3/4	1	D(a1)-E(a)	105	110	396	35	8,5			
		1	1	D(a1)-E(a)									
		UNI PN 64 ÷ 100 ANSI 600	3/4	1	D(a1)-E(a)								
		1	1	D(a1)-E(a)									
	1 <sup>st</sup> series 3-5361	ANSI 300 ÷ 1500	ANSI 150 ÷ 600	1/2	3/4	D(a1)-E(a)	110	150	379		4,5		
				1/2	1	D(a1)-E(a)							
				3/4	1	D(a1)-E(a)							
	2 <sup>nd</sup> series 3-5363			2 <sup>nd</sup> series L 3-5364	3/4	1	D(a1)-E(a)	150	150	409			7
					1	1	D(a1)-E(a)						
					1	1.1/2	D(a1)-E(a)						
	2 <sup>nd</sup> series L 3-5364			2 <sup>nd</sup> series L 3-5364	3/4	1	D(a1)-E(a)	150	150	436			7,5
					1	1	D(a1)-E(a)						
2 <sup>nd</sup> series L 3-5364	2 <sup>nd</sup> series L 3-5364	1	1.1/2	D(a1)-E(a)	150	150	436			7,5			
		1	1.1/2	D(a1)-E(a)									

- (1) Add 36 mm to dimension C when considering valves with lifting lever
- (2) Free height above cap for disassembling: 100 mm
- (3) Add 0,5 kg when considering valves with lifting lever
- (4) The orifices with the (a) suffix are recommended on liquid services

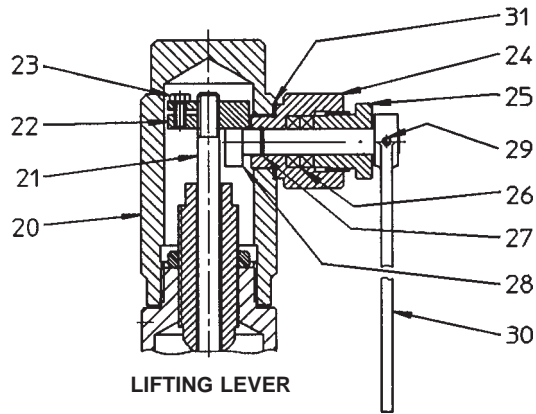

LIFTING LEVER

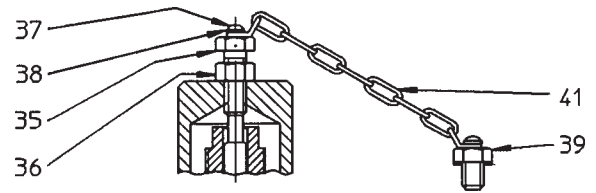

TEST GAG

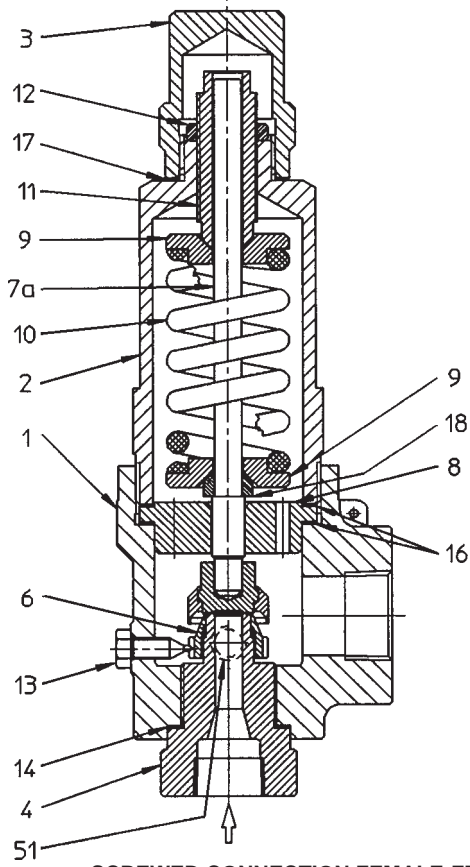

SCREWED CONNECTION FEMALE-FEMALE

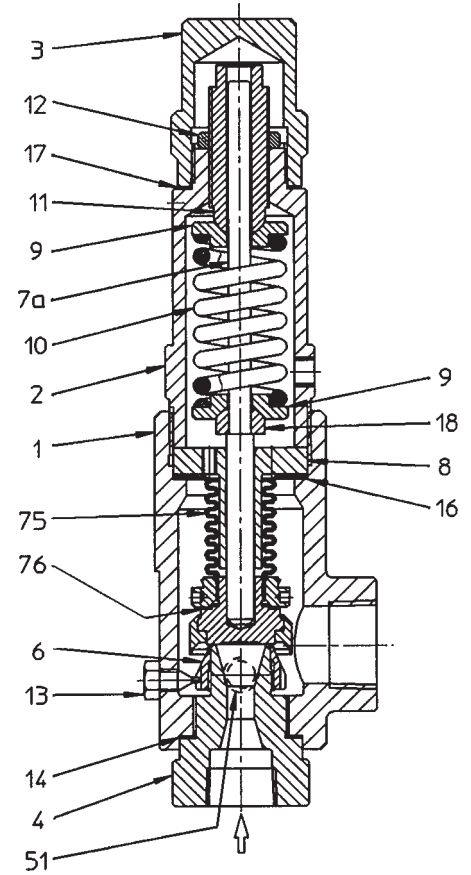
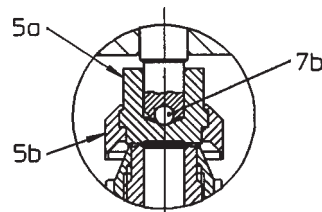

SCREWED CONNECTION FEMALE-FEMALE WITH BELLOWS

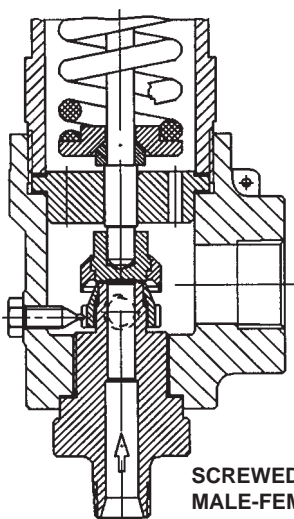

SCREWED CONNECTION MALE-FEMALE

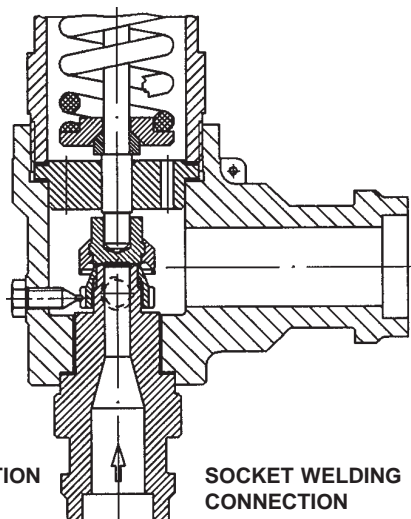

SOCKET WELDING CONNECTION

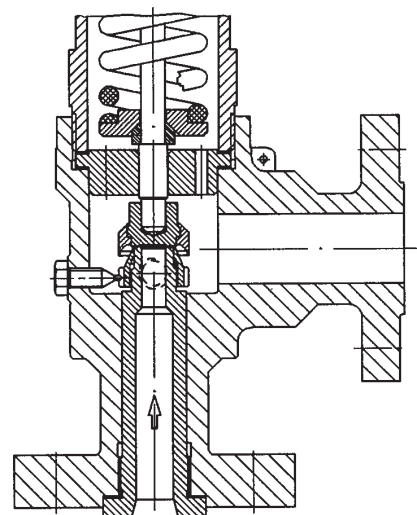

FLANGED CONNECTION

**BODY BASIC CLASS**

Item	Part Name	Materials – basic classes (1) (specify the subclass too)	
		A	G
1	Body	A 105	AISI 316
4	Nozzle	SEE SUBCLASSES TABLE	
5a	Disc	SEE SUBCLASSES TABLE	
5b	Disc holder	AISI 316	AISI 316
6	Adjusting ring	AISI 316L	AISI 316L
13	Locking screw	AISI 304	AISI 304

**BONNET BASIC CLASS**

Item	Part Name	Basic classes (1)	
		A	G
2	Bonnet	A 105	AISI 316
3	Std cap	A 105	AISI 316
7a	Stem	AISI 420	AISI 316
7b	Ball	AISI 420	AISI 316
8	Guide	AISI 316	AISI 316
9	Spring seat	Carbon steel	AISI 316
10	Spring	SEE SPRING SUBCLASS TABLE	
11	Spring adjusting screw	AISI 416	AISI 316
12	Nut	AISI 304	AISI 304
14	Nozzle gasket	Synthetic compound*	Synthetic compound*
16	Guide gasket	Synthetic compound*	Synthetic compound*
17	Cap gasket	Synthetic compound*	Synthetic compound*
18	Ball – and – socket joint	17-4-PH	S 21800
20	Manual lift cap	A 105	AISI 316
21	Manual lift stem	AISI 420	AISI 316
22	Stop disk	Carbon steel	AISI 316
23	Screw	AISI 304	AISI 304
24	Support	A 105	AISI 316
25	Packing gland	Carbon steel	AISI 316
26	Packing	Graphited Teflon	Graphited Teflon
27	Circlip	AISI 316	AISI 316
28	Shaft	AISI 416	AISI 316
29	Dowel	AISI 304	AISI 304
30	Lever	Carbon steel	Carbon steel
31	Support gasket	Synthetic compound*	Synthetic compound*
35	Test gag	AISI 304	AISI 304
36	Test gag nut	AISI 304	AISI 304
37	Screwed rivet	C 15	C 15
38	Washer	AISI 304	AISI 304
39	Plug	AISI 304	AISI 304
41	Chain	Carbon steel	Carbon steel
45	Plate	AISI 304	AISI 304
46	Pivot	Aluminum	Aluminum
51	Drain plug	Carbon steel	AISI 316
75	Bellows	AISI 316L	AISI 316L
76	Bellows gasket	Synthetic compound*	Synthetic compound*

\*over 300 °C armoured graphite

(1) AISI 316L, HASTELLOY C276, MONEL 400, INCOLOY 825, MONEL, INCONEL 600 and other materials are available on request.

SUBCLASS (1)	Item	4	5a
	Part Name	Nozzle	Disc
	01	AISI 316	17-4-PH H900
	02		AISI 316
	03		AISI 316+stellite gr. 6
	04	AISI 316+stellite gr. 6	17-4-PH H900
	05		AISI 316+stellite gr. 6
	06	AISI 316	17-4-PH H1150
07	AISI 316+stellite gr. 6		

(1) AISI 316L, HASTELLOY C276, MONEL 400, INCOLOY 825, MONEL, INCONEL 600 and other materials are available on request.

SPRING SUBCLASS	Item	10	Fluid temperature - °C (2)		
	Part Name	Spring	Min	Max	
				Tight Bonnet	Vented Bonnet
	C	Carbon Steel	-60	+230	+380
S	AISI 316	-200	+300	+450	
W	Tungsten Steel	-30	+550	+560	
P	17-4-PH H1025	-50	+450	+560	
H	17-4-PH H1150	-100	+450	+560	
Y	17-7-PH CH900	-30	+470	+560	
L	INCONEL X 750	-200	+400	+550	
T	INCONEL X 750 TTT	-200	+560	+560	

(2) Values refer to open valve with ambient temperature -20 ÷ +30 °C.

## AVAILABLE STANDARD COMBINATIONS

Fluid temperature - °C

Subclass	Basic class (*) body-bonnet		
	AA	GA	GG
01	-30 ÷ +430	-30 ÷ +430	-30 ÷ +450
02		-30 ÷ +400	-200 ÷ +400
03		-30 ÷ +430	-200 ÷ +450
04	-30 ÷ +430	-30 ÷ +430	-30 ÷ +450
05		-30 ÷ +430	-200 ÷ +450
06			-100 ÷ +450
07			-100 ÷ +450

**Classification example: GA 01 C**  
 body material = AISI 316  
 bonnet material = A 105  
 nozzle material = AISI 316  
 disc material = 17-4-PH H900  
 spring material = carbon steel  
 temperature limits = -30 ÷ +230 °C

(\*) ex.: AA = body class A + bonnet class A





**PARCOL S.p.A.** Via Isonzo, 2 - **20010 CANEGRATE** (MI) - ITALY

Telephone: +39 0331 413 111 - Fax: +39 0331 404 215

e-mail: [sales@parcol.com](mailto:sales@parcol.com) - <http://www.parcol.com>